

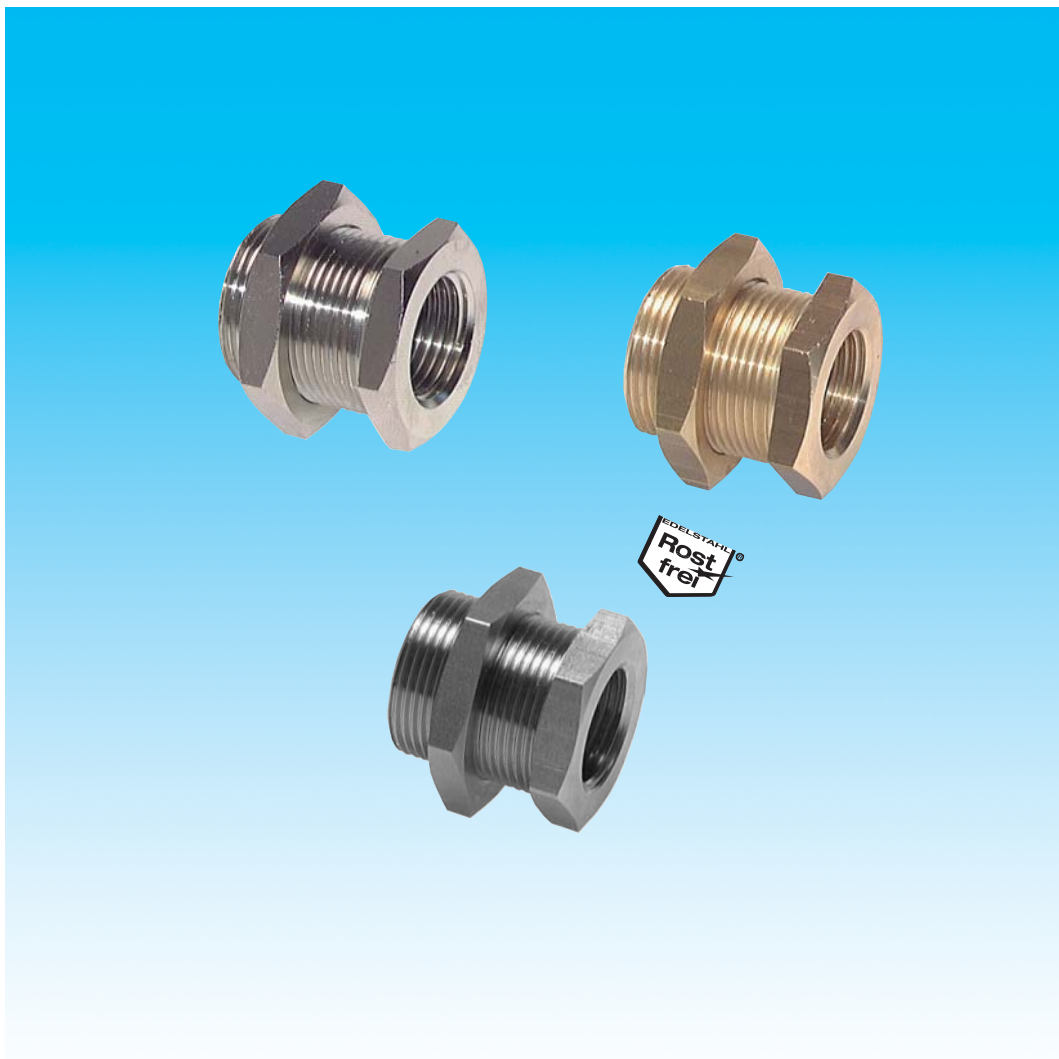

Dokumentation

Schottverschraubungen

- Typ SV ... -



Schottverschraubungen			bis 40 bar			
Typ 16 bar MS vernickelt	Typ 16 bar Messing	Typ 40 bar 1.4571 	Gewinde innen	Schottge- winde G	E max.	Einbau- bohrung Ø
SV 50 MSV	SV 50 MS	---	M5	G 1/8"	8,0	10,0
SV 18 MSV	SV 18 MS	SV 18 ES	G 1/8"	G 1/4"	10,0	14,0
SV 14 MSV	SV 14 MS	SV 14 ES	G 1/4"	G 3/8"	14,0	17,0
SV 38 MSV	SV 38 MS	SV 38 ES	G 3/8"	G 1/2"	16,0	21,5
SV 12 MSV	SV 12 MS	SV 12 ES	G 1/2"	M28 x 1,5	20,0	28,5
SV 34 MSV	SV 34 MS	SV 34 ES	G 3/4"	M34 x 2	24,0	34,5
---	SV 10 MS	SV 10 ES	G 1"	M42 x 2	26,0	42,5
---	SV 114 MS	SV 114 ES	G 1 1/4"	M49 x 2	29,5	49,5
---	SV 112 MS	SV 112 ES	G 1 1/2"	M54 x 2	29,0	54,5

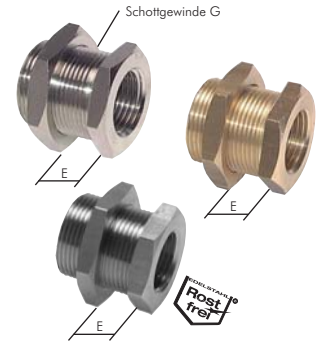

Zeichnung/Abmaße

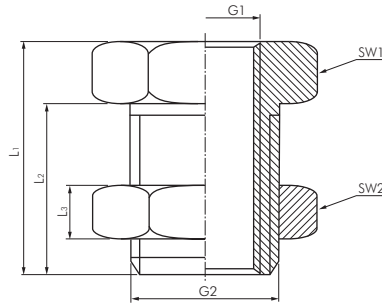

Typ 16 bar MS vernickelt	Typ 16 bar Messing	Typ 40 bar 1.4571 	Gewinde innen G1	Schottge- winde G2	E max.	Einbau- bohrung Ø	SW1	SW2	L1	L2	L3
SV 50 MSV	SV 50 MS	---	M5	G 1/8"	8,0	10,0	14	14	15	12	4
SV 18 MSV	SV 18 MS	SV 18 ES	G 1/8"	G 1/4"	10,0	14,0	17	17	18	14	4
SV 14 MSV	SV 14 MS	SV 14 ES	G 1/4"	G 3/8"	14,0	17,0	22*	22	22	18**	4***
SV 38 MSV	SV 38 MS	SV 38 ES	G 3/8"	G 1/2"	16,0	21,5	24	27	26	21	5
SV 12 MSV	SV 12 MS	SV 12 ES	G 1/2"	M28 x 1,5	20,0	28,5	32	36	33	27	7
SV 34 MSV	SV 34 MS	---	G 3/4"	M34 x 2	24,0	34,5	41	41	36	30	6
---	SV 10 MS	---	G 1"	M42 x 2	26,0	42,5	46	50	42	34	8
---	SV 114 MS	---	G 1 1/4"	M49 x 2	29,5	49,5	55	55	47	39	9,5
---	SV 112 MS	---	G 1 1/2"	M54 x 2	29,0	54,5	60	60	47	39	10

* Typ SV 14 ES = 19, ** Typ SV 14 ES = 17, *** Typ SV 14 ES = 5